

# FT-106 Powys Fountain



## FOUNTAIN INFORMATION:

**This fountain holds approximately 2 gallons of water.**

**This fountain uses a small fountain cover.  
(FTNCOV-SM)**

**No refill device or submersible lights are suggested for  
this fountain**

## Pump Kit Parts List

PK120 pump (1)  
#7 stopper (1)  
6" length of 1/2" black non-kink tubing (1)  
Hose clamps (2) \*  
Wedges (2)

\* Hose clamps may be used as flow restrictors

## TOOLS REQUIRED:

Bubble Level



## PUMP INFORMATION:

**PES120 - 120 GPH Pump  
5 FT cord length**

## - W I N T E R   C A R E -

Fountain bowls/tops and other fountain components, which collect water, should not be left outside in the winter since any component, which fills with water and freezes may crack. Likewise, components such as pedestals, which remain in a basin, filled with water, which then freezes, may also crack or crumble. Ideally, therefore, a fountain should always be stored indoors or in a dry protected place such as a covered porch away from the elements. However, if a fountain must be left outside:

- (1) Remove pump, rubber stoppers, drainpipes, finials, and other small components for storage indoors. Note that stoppers or drainpipes are removed to allow drainage in the event water accumulates in any basin.
- (2) Raise fountain base from ground with wood strips so that base will not freeze to the ground surface.
- (3) Cover or wrap the fountain with burlap or other absorbent material (old blanket or towel) and then cover securely with plastic, making sure that water will not accumulate in the basin or other fountain component and freeze;
- (4) Check fountain periodically to insure that plastic is secure and water is not accumulating in any fountain component.

## - G E N E R A L   F O U N T A I N   T I P S -

**Install fountains on a level surface.** You will need a properly grounded 110-volt (AC only) GFCI protected receptacle near the fountain for your pump. All pumps are submersible and must be completely underwater to function properly. Test all pumps and adjust to full output prior to assembly. It is not recommended that fountains be placed directly on grass or dirt. Position the channel opening at the base of each fountain toward the electrical outlet to be used since the pump cord will be threaded through this opening.

All of our cast stone is proudly



**Made in USA**

Check out YouTube for a "How to" video.

For more Campania product information visit [www.campaniainternational.com](http://www.campaniainternational.com)

# FT-106 Powys Fountain

Assemble your fountain on a level surface capable of holding a minimum of 134 pounds with an approximate 6 square inch footprint.



FT-106B (92 lbs)  
18.25"W x 25.25" H

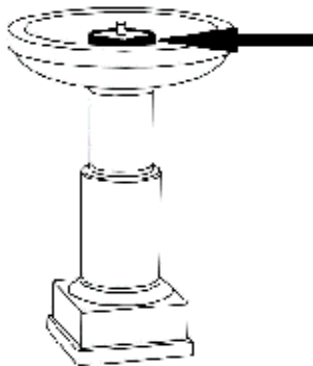

FT-106C (3 lbs)  
5.25"W x 2" H

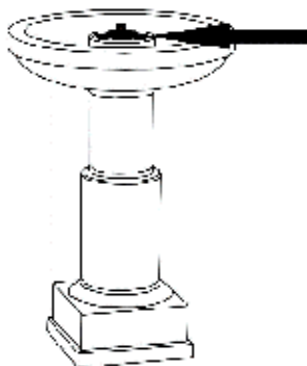

FT-106A (3 lbs)  
3.75"W x 1.25" H

1. Position the basin (FT-106B) where the fountain is to be installed, ensuring that it is level.
2. Assemble the pump kit
  - a. Using a hose clamp, attach the 1/2" non-kink tubing to the pump outlet.
  - b. Place the stopper around the pump cord approximately 6 inches from the pump.
3. Feed the pump cord through the hole in the basin (FT-106B) and out of the channel.
4. **FIRMLY** press the stopper into the hole evenly.
  - a. Note: Using the handle of a screwdriver or hammer works best to press the stopper in place.
5. Place the pump cover (FT-106C) over the pump.
6. Use a hose clamp to attach the loose end of the tubing into the bottom of the water feature (FT-106A).
7. Place the water feature into the basin ensuring that it is level.
  - a. Turn the feature and coil the tubing as you lower it into position.
8. Fill the fountain with water.